

# Piaggio Ape B – 150 cc

Ape B - 150cc



1953

AB1T

1001-10940

1954

AB1T

10941-13969

1954

AB2T

13970-19037

1955

AB3T

19038-28050

1956

AB4T

28051-34550

Motore 150 cc, cambio non più a bacchetta, fano basso, mozzo a dx del parafango





## D I M E N S I O N I

### TELAIO

Carreggiata . . . mm. 1.050  
Interasse ruote . . . mm. 1.590  
Raggio di volta . . . mm. 1.885

### PIANALE NORMALE

Larghezza massima . mm. 1.300  
Dimensioni interne  
mm. 1.100×1.100×220

### PIANALE METALLICO

Larghezza massima . mm. 1.300  
Dimensioni interne  
mm. 1.100×1.100×220

### RIBALTABILE

Larghezza massima . mm. 1.300  
Dimensioni interne  
mm. 1.100×1.100×220

### FURGONCINO METALLICO

Larghezza massima . mm. 1.300  
Dimensioni interne  
mm. 1.100×1.100×700

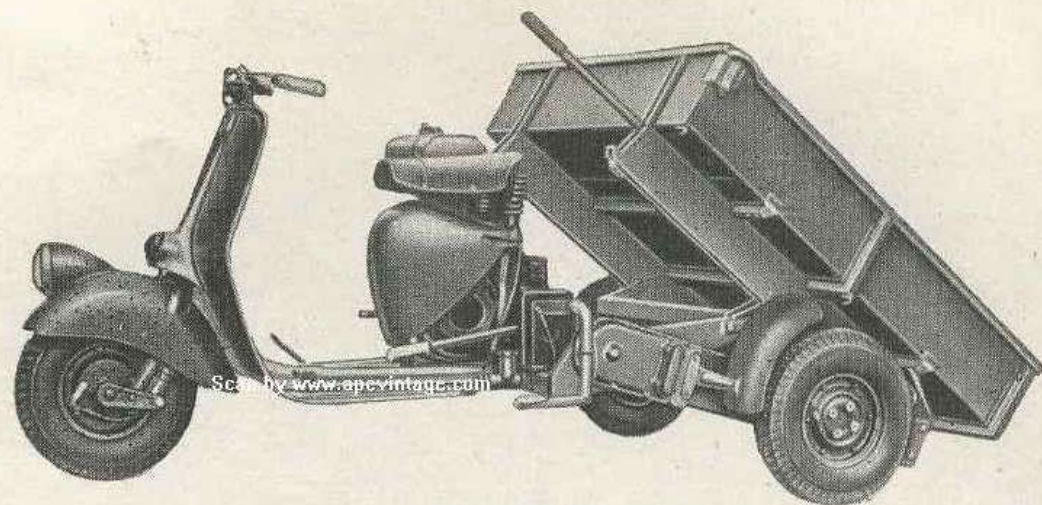

RIBALTABILE



FURGONCINO METALLICO





# MOTOCARROZZETTA APE 150 c.c.

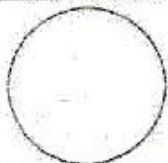

OMOLOGATO DALL'ISPETTORATO GENERALE DELLA MOTORIZZAZIONE CIVILE  
E DEI TRASPORTI IN CONCESSIONE CON ATTO N. 293 DEL 27 - 1 - 53

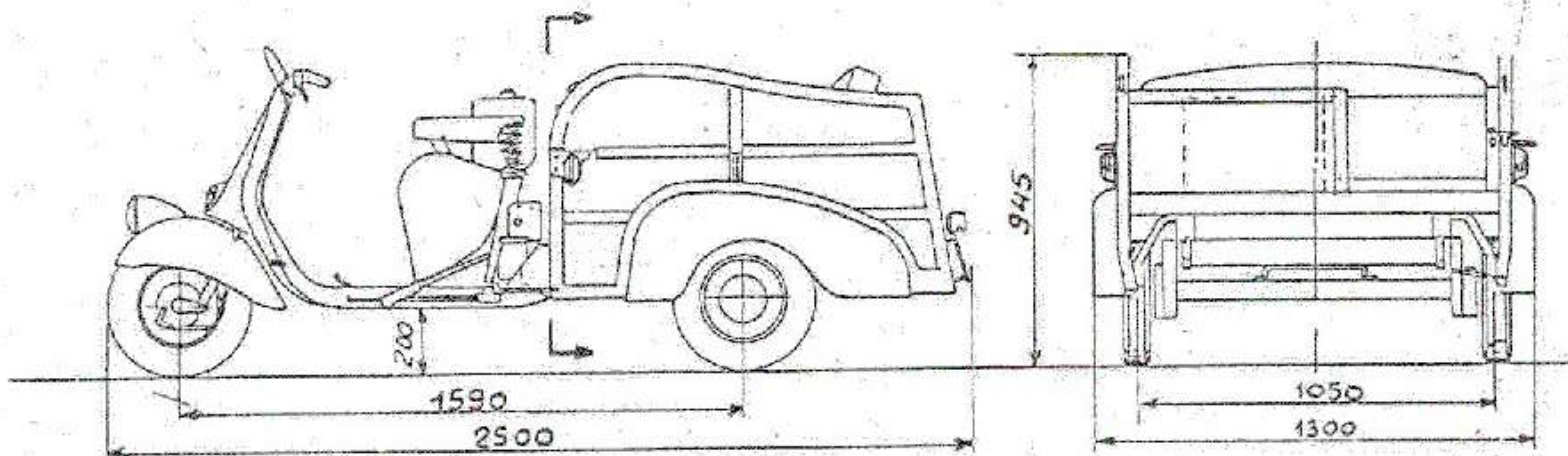

## DIMENSIONI E PESI

Lunghezza massima	mt. 2,500
Larghezza massima	mt. 1,300
Altezza massima	mt. 0,945
Altezza minima dal suolo	mt. 0,200
Passo	mt. 1,590
Carreggiata	mt. 1,050
Sbalzo posteriore	mt. 0,64
Raggio minimo di sterzata	mt. 1,700
Posti (compreso il conducente)	n. 3
Peso a vuoto in ordine di marcia	Kg. 235

## MOTORE

2 tempi	
Numero dei cilindri	1
Alesaggio	mm. 58,5
Corsa	mm. 54
Cilindrata totale	cm <sup>3</sup> 145,2
Potenza effettiva al regime di 5000 giri/minuto	CV. 5,5
Potenza fiscale	CV. 3
Rapporto di compressione	6,2
Accensione con magnete a volano	
Lubrificazione a miscela benzina - olio	
Avviamento con leva a mano	

INNESTO A FRIZIONE a dischi multipli in bagno d'olio. Comando mediante leva sul manubrio.  
CAMBIO DI VELOCITÀ a 4 marce con comando a mano sulla manopola sinistra abbinato con la frizione.







A

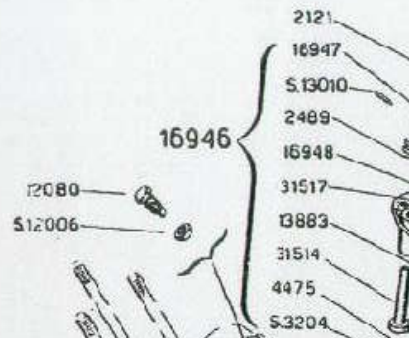

B

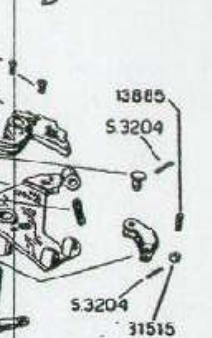

C

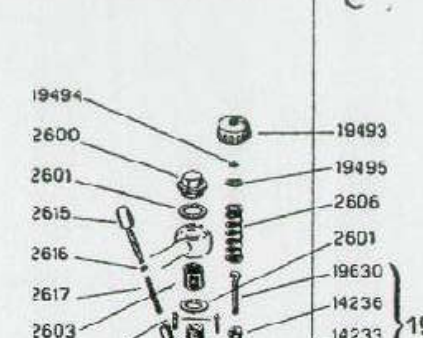

D

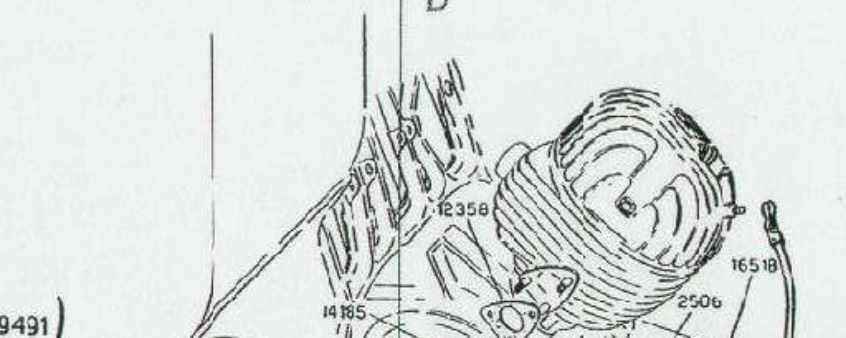

E

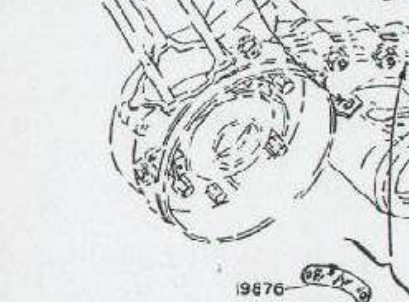

F

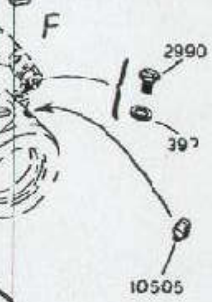

I

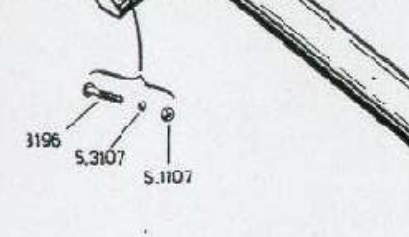

L

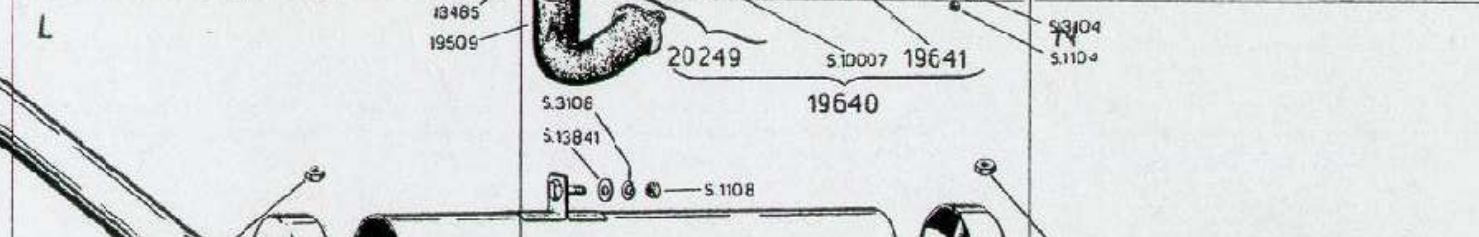

O



P

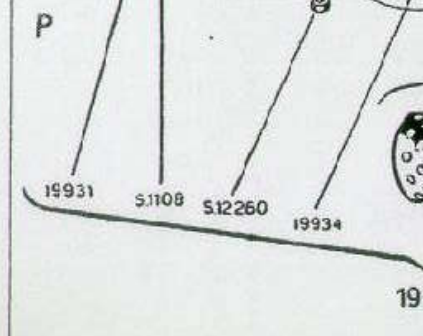

Q

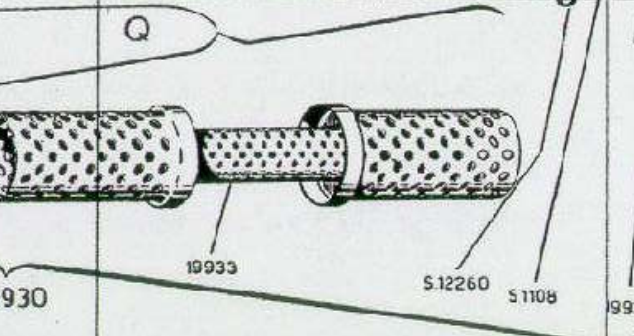

R





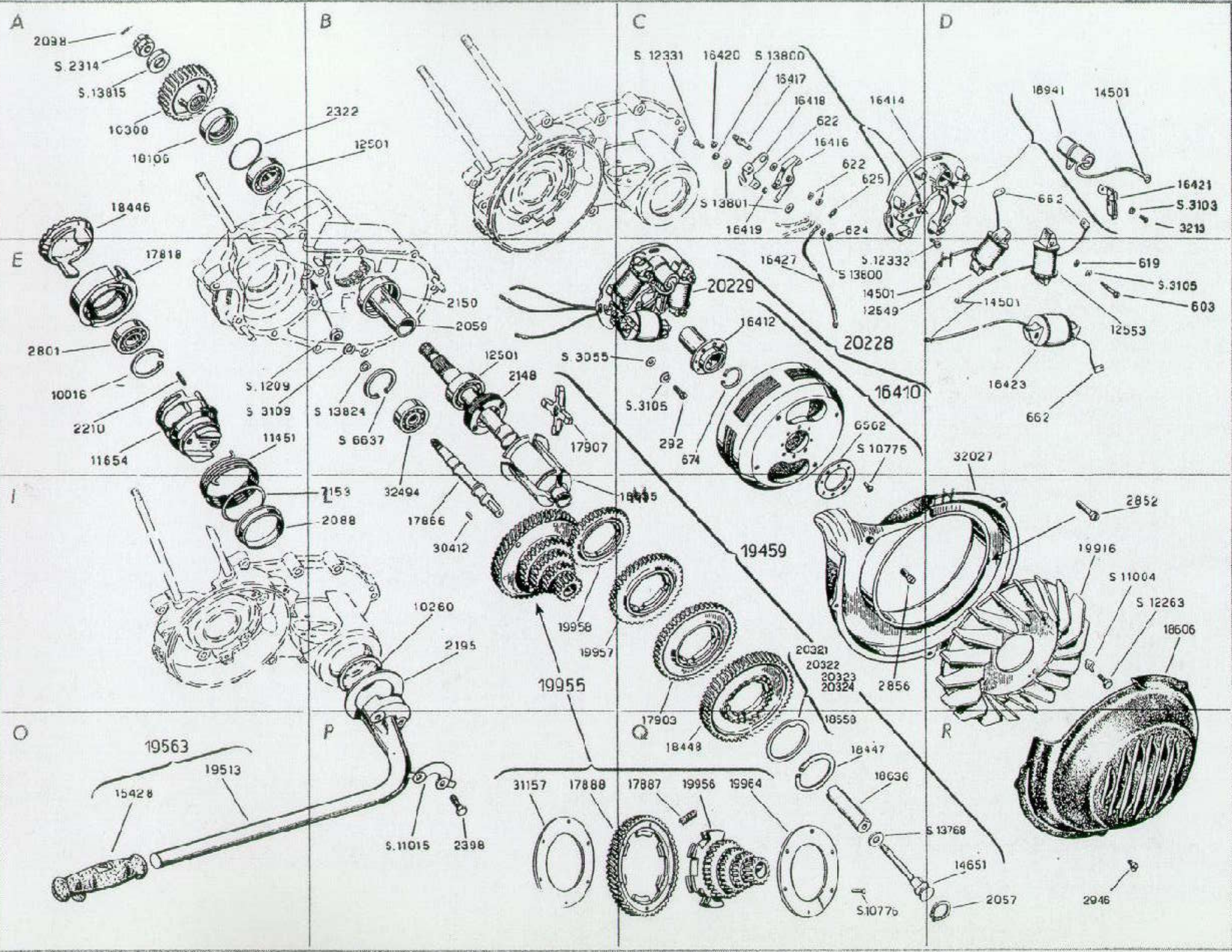



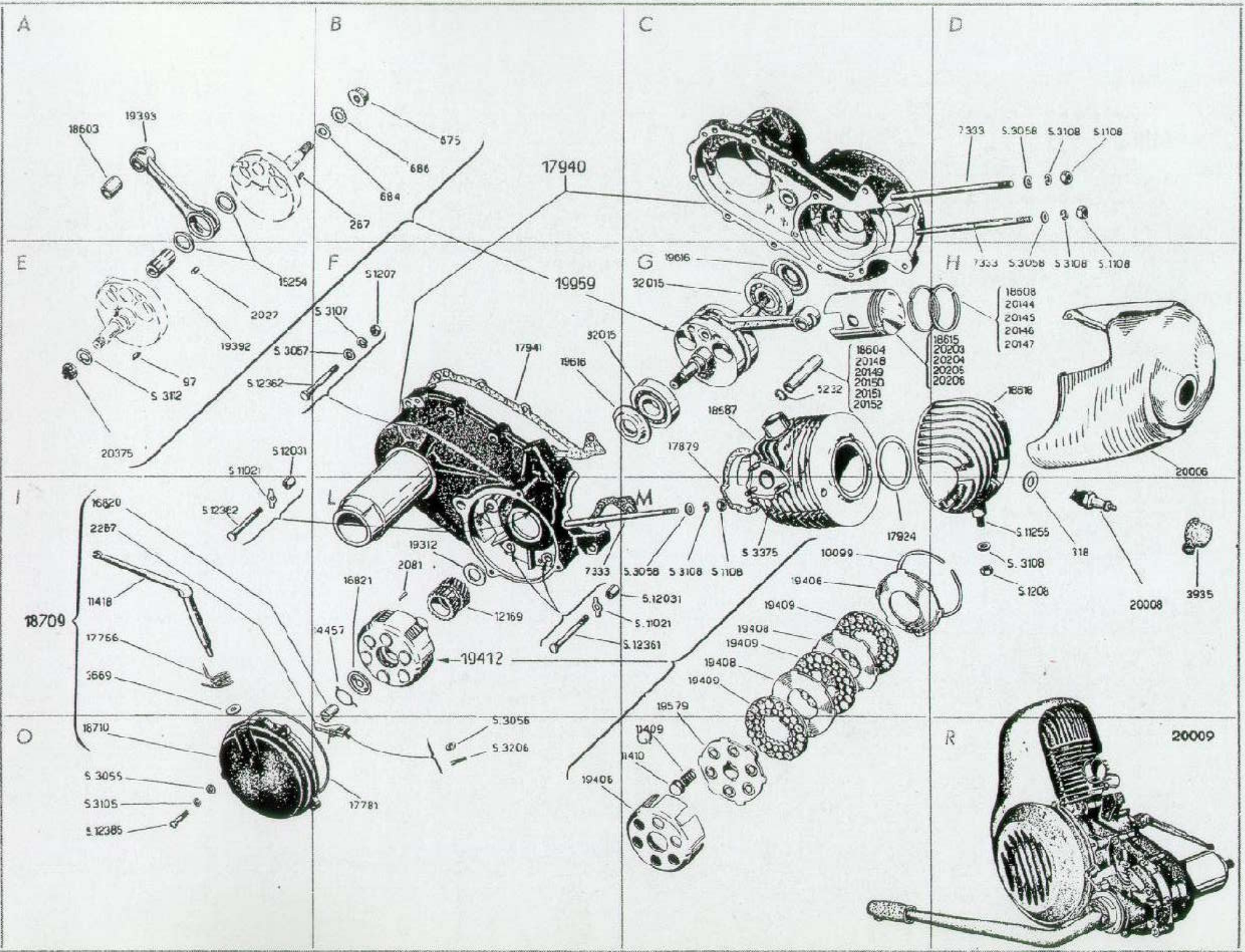



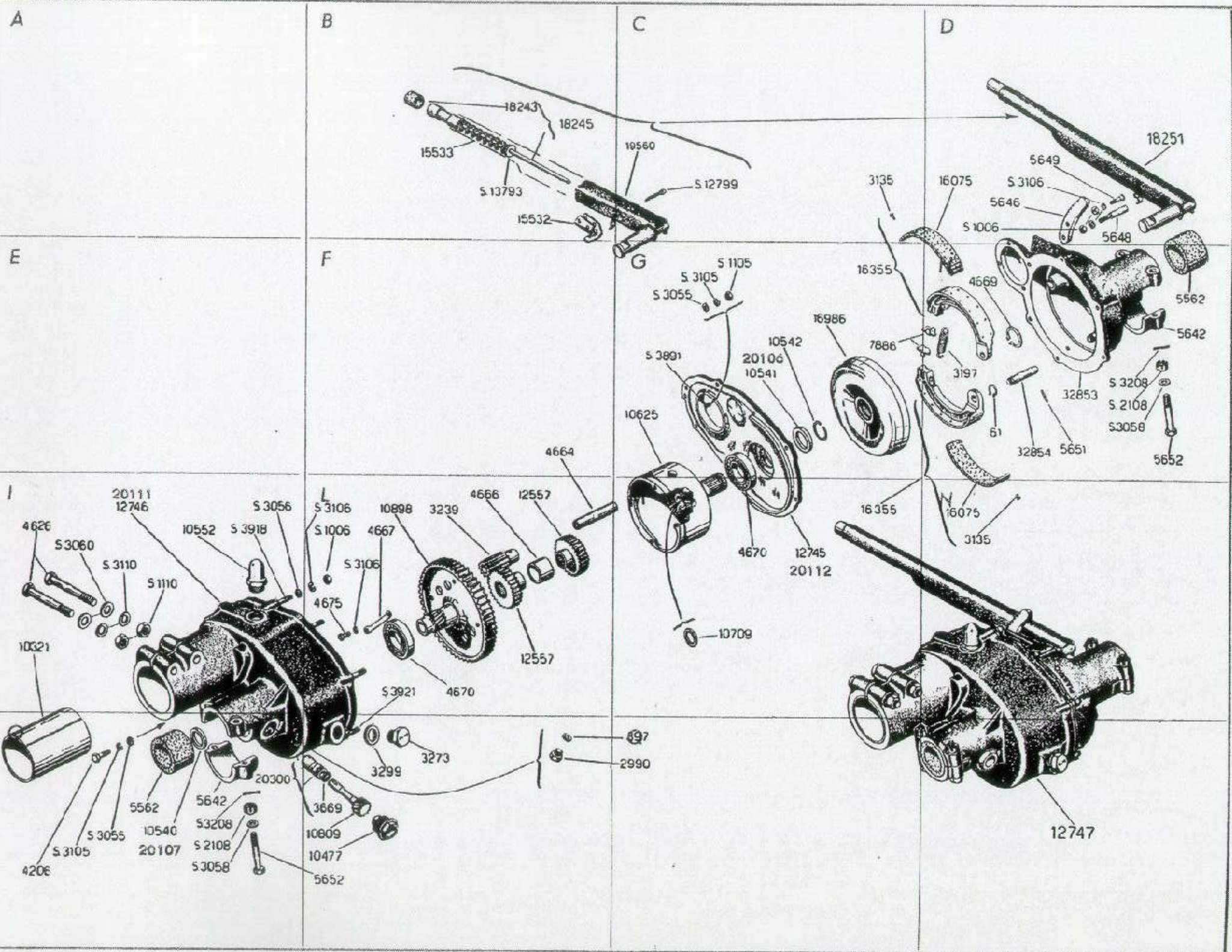

A

B

C

D

E

F

G

I

L

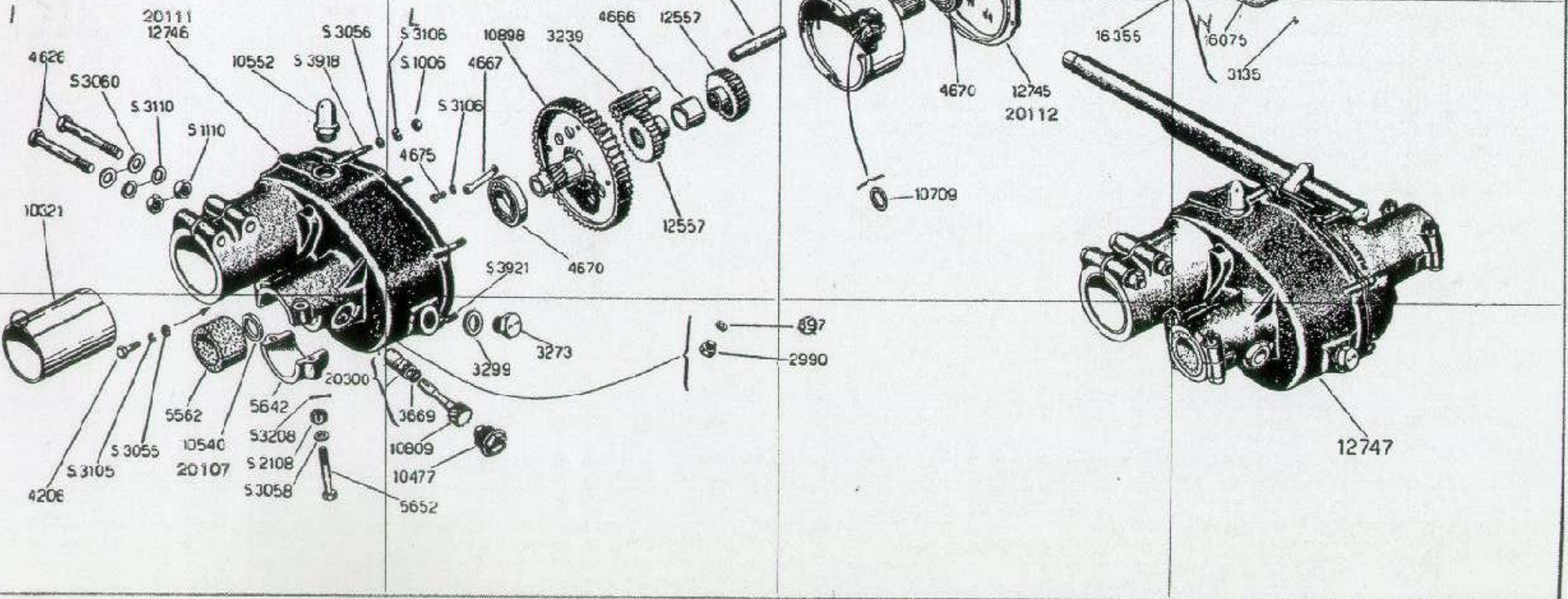







A

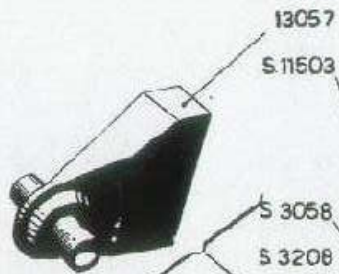

B

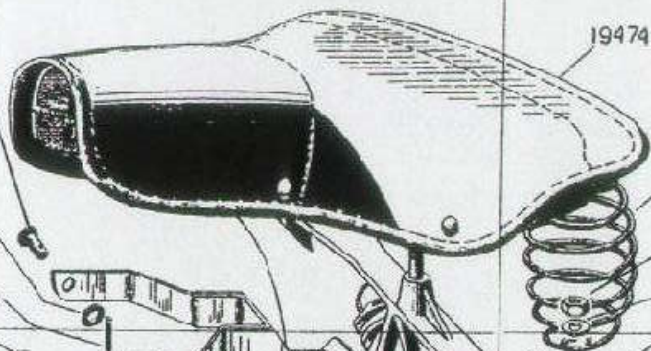

C

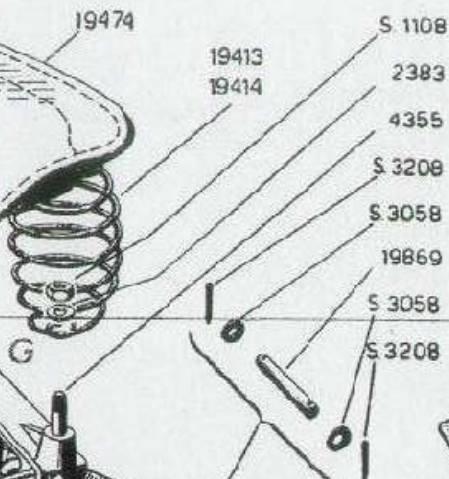

D

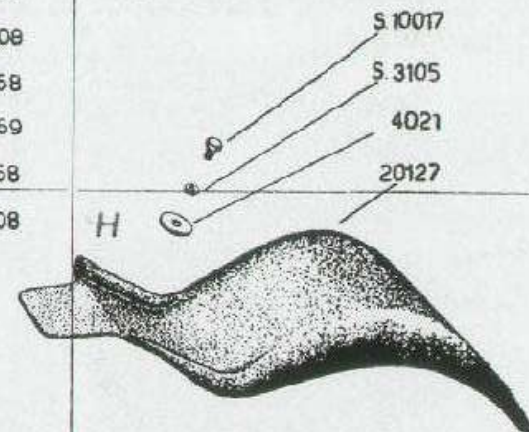

E

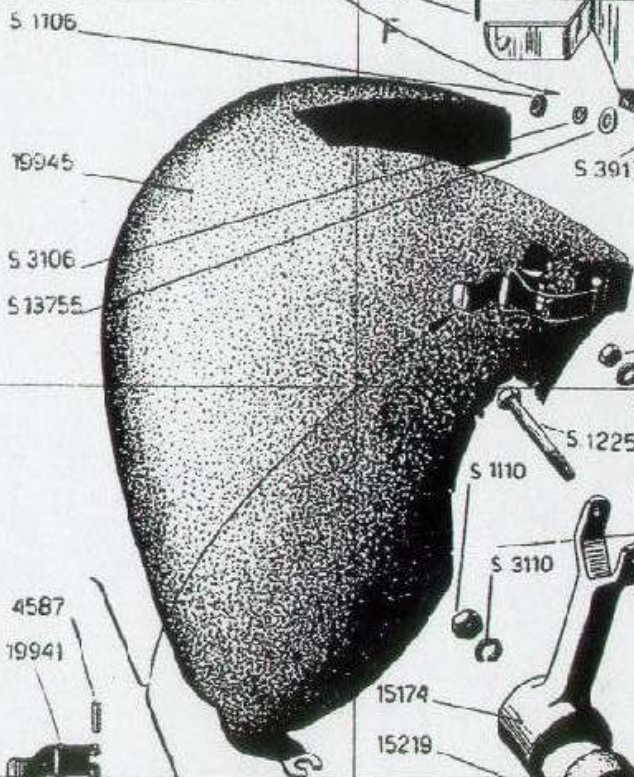

F

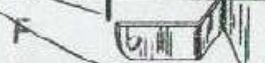

G

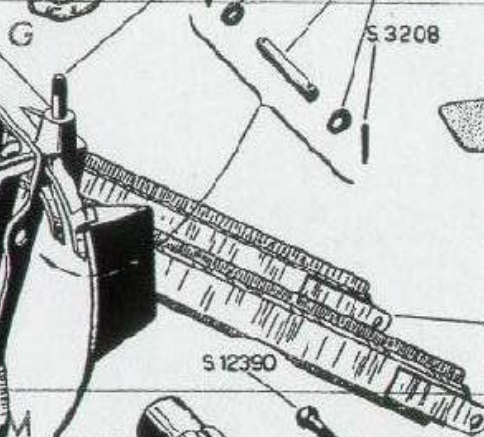

H



I

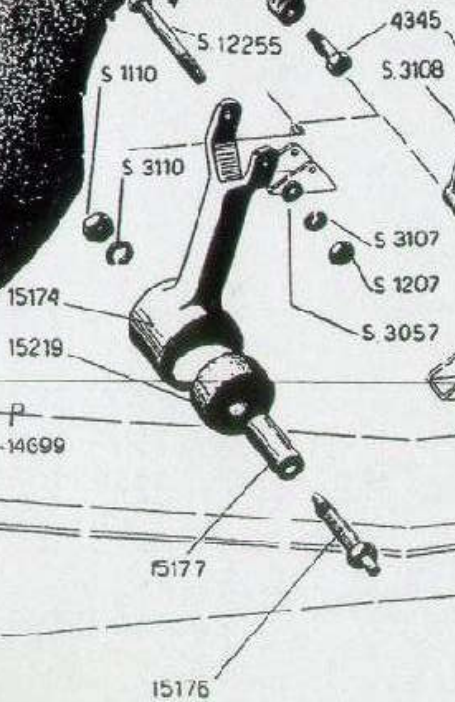

M

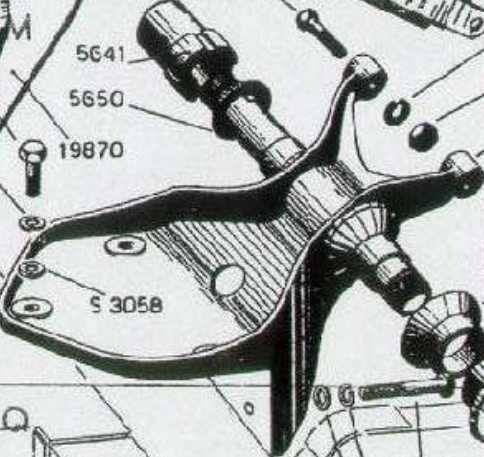

N

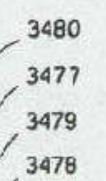



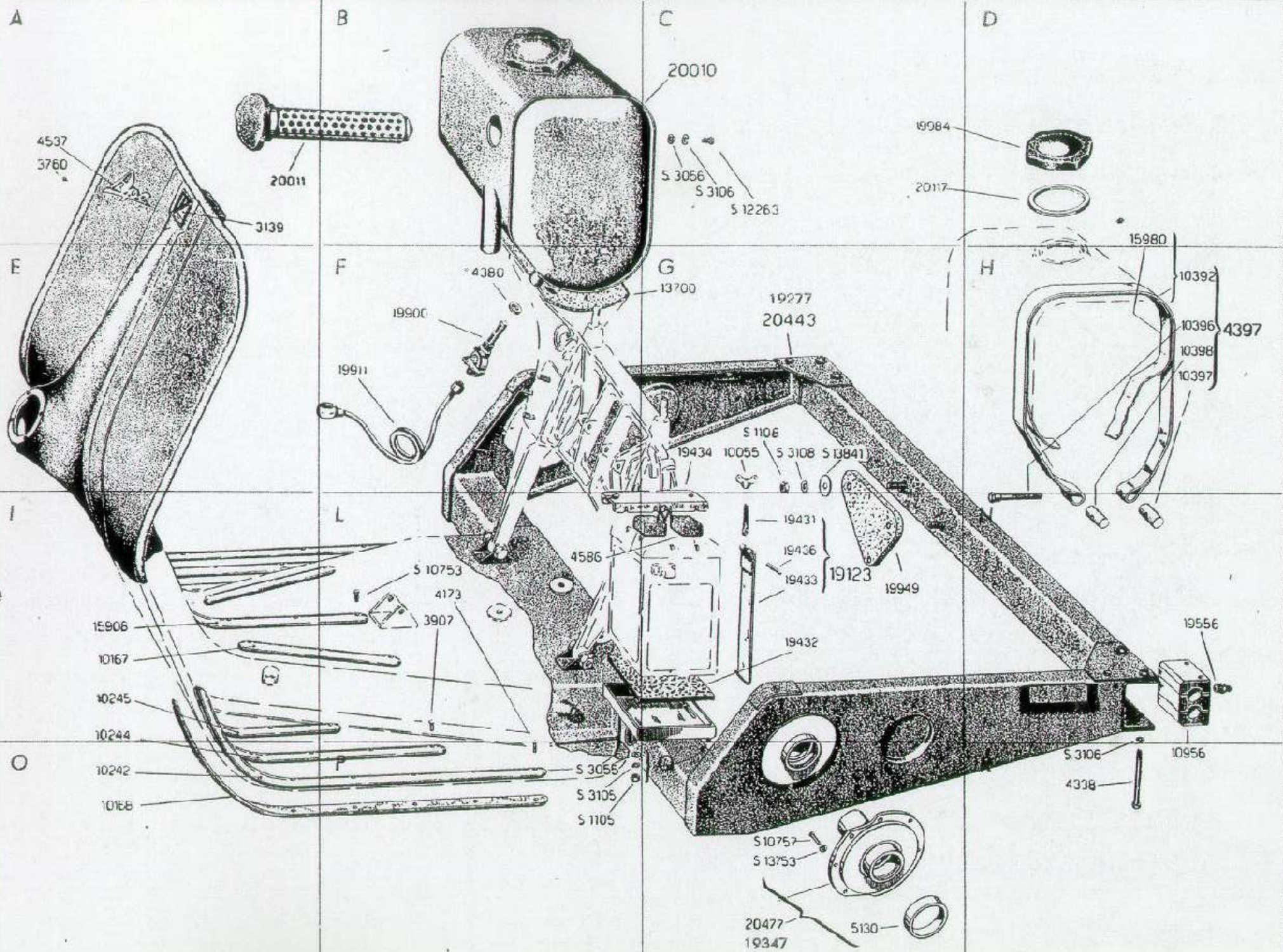



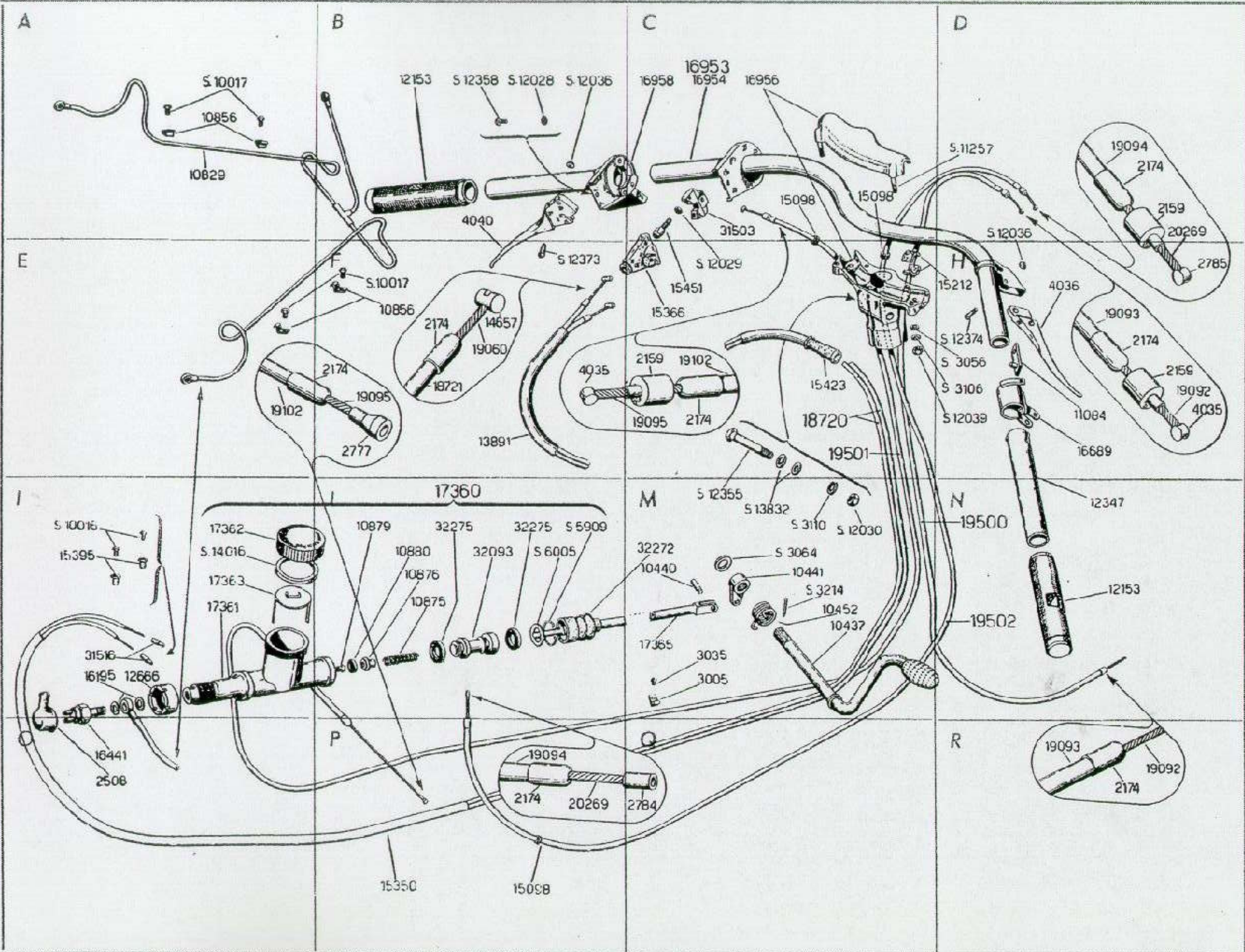







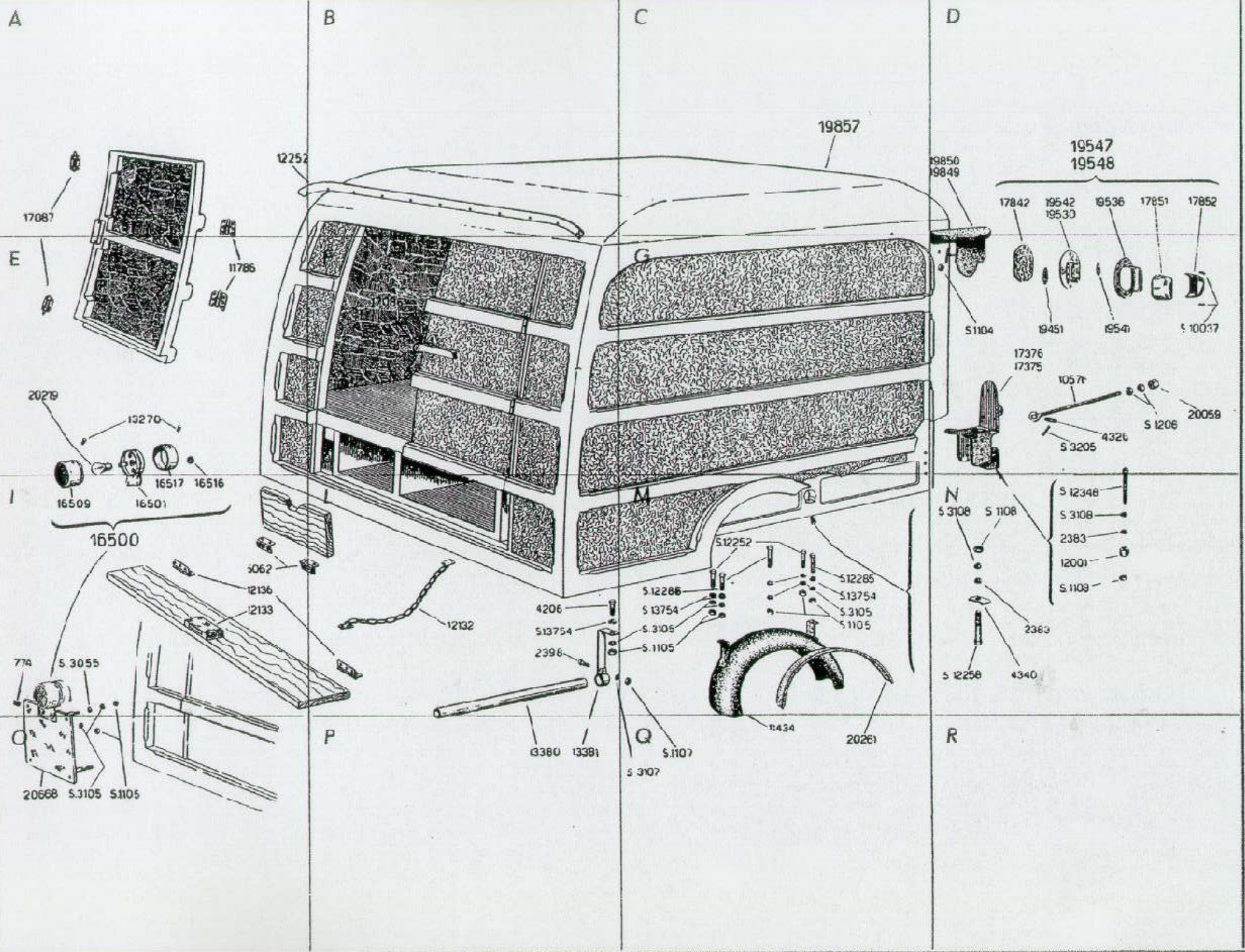



A

B

C

D

